



►FMM250 7 229 36  
►FMM250Q 7 229 37

**MULTIMASTER**

**FEIN Service**

**USA**

FEIN Power Tools Inc.  
1030 Alcon Street  
Pittsburgh, PA 15220  
Telephone: (412) 922-8886  
Toll Free: 1-800-441-9878  
www.fein.us

**Canada**

FEIN Canadian Power Tool  
Company  
323 Traders Boulevard East  
Mississauga, Ontario L4Z 2E5  
Telephone: (905) 8901390  
Toll Free: 1-800-265-2581

FEIN Canadian Power Tool  
Company  
2810 De Miniac  
St. Laurent, Quebec H4S 1K9  
Telephone: (514) 331-7390  
Toll Free: 1-800-789-8181  
www.fein.com

**Headquarter**



C. & E. FEIN GmbH  
Hans-Fein-Straße 81  
D-73529 Schwäbisch Gmünd-Bargau

[www.fein.com](http://www.fein.com)

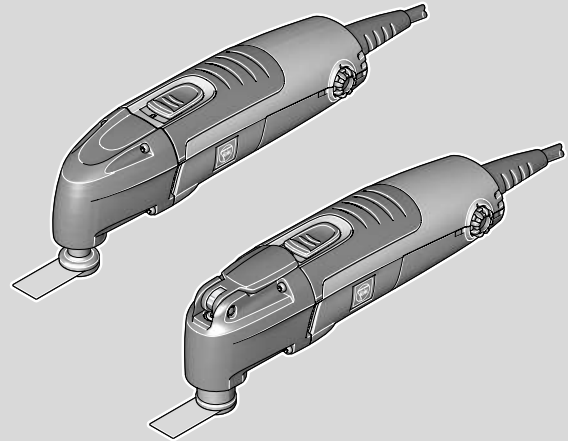
© C. & E. FEIN GmbH. Printed in Germany. Abbildungen unverbindlich. Technische Änderungen vorbehalten. 3 41 01 091 21 0 BY 2007/ZZZ/DE.

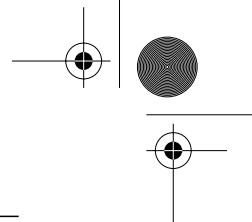



<b>English</b>	<b>Instruction manual</b>	 3
<b>Français</b>	<b>Mode d'emploi</b>	 17
<b>Español</b>	<b>Instrucciones de uso</b>	 31

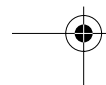
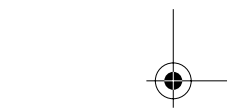
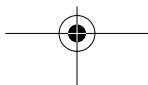
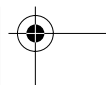
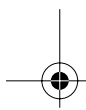
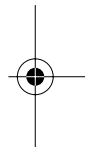
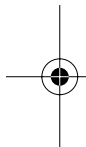



## For your safety.

Only carry out such operations with this power tool as intended for by FEIN. Only use application tools and accessories that have been released by FEIN.

Do not use this power tool before you have thoroughly read and completely understood this Instruction Manual, including the figures, specifications, safety regulations and the signs indicating DANGER, WARNING and CAUTION.

Please also observe the relevant national industrial safety regulations.

Non-observance of the safety instructions in the said documentation can lead to an electric shock, burns and/or severe injuries. This Instruction Manual should be kept for later use and enclosed with the power tool, should it be passed on or sold.

### **WARNING! Read all instructions.**

#### **SAVE THESE INSTRUCTIONS**

##### **1) Work area safety**

- a) **Keep work area clean and well lit.** Cluttered or dark areas invite accidents.
- b) **Do not operate power tools in explosive atmospheres, such as in the presence of flammable liquids, gases or dust.** Power tools create sparks which may ignite the dust or fumes.
- c) **Keep children and bystanders away while operating a power tool.** Distraction can cause you to lose control.

##### **2) Electrical safety**

- a) **Power tool plugs must match the outlet. Never modify the plug in any way. Do not use any adapter plugs with earthed (grounded) power tools.** Unmodified plugs and matching outlets will reduce risk of electric shock.

- b) **Avoid body contact with earthed or grounded surfaces such as pipes, radiators, ranges and refrigerators.** There is an increased risk of electric shock if your body is earthed or grounded.
- c) **Do not expose power tools to rain or wet conditions.** Water entering a power tool will increase the risk of electric shock.
- d) **Do not abuse the cord. Never use the cord for carrying, pulling or unplugging the power tool. Keep cord away from heat, oil, sharp edges or moving parts.** Damaged or entangled cords increase the risk of electric shock.
- e) **When operating a power tool outdoors, use an extension cord suitable for outdoor use.** Use of a cord suitable for outdoor use reduces the risk of electric shock.

##### **3) Personal safety**

- a) **Stay alert, watch what you are doing and use common sense when operating a power tool. Do not use a power tool while you are tired or under the influence of drugs, alcohol or medication.** A moment of inattention while operating power tools may result in serious personal injury.
- b) **Use safety equipment. Always wear eye protection.** Safety equipment such as dust mask, non-skid safety shoes, hard hat, or hearing protection used for appropriate conditions will reduce personal injuries.
- c) **Avoid accidental starting. Ensure the switch is in the off-position before plugging in.** Carrying power tools with your finger on the switch or plugging in power tools that have the switch on invites accidents.

- d) **Remove any adjusting key or wrench before turning the power tool on.** A wrench or a key left attached to a rotating part of the power tool may result in personal injury.
- e) **Do not overreach. Keep proper footing and balance at all times.** This enables better control of the power tool in unexpected situations.
- f) **Dress properly. Do not wear loose clothing or jewelry. Keep your hair, clothing and gloves away from moving parts.** Loose clothes, jewelry or long hair can be caught in moving parts.
- g) **If devices are provided for the connection of dust extraction and collection facilities, ensure these are connected and properly used.** Use of these devices can reduce dust-related hazards.
- 4) Power tool use and care**
- a) **Do not force the power tool. Use the correct power tool for your application.** The correct power tool will do the job better and safer at the rate for which it was designed.
- b) **Do not use the power tool if the switch does not turn it on and off.** Any power tool that cannot be controlled with the switch is dangerous and must be repaired.
- c) **Disconnect the plug from the power source and/or the battery pack from the power tool before making any adjustments, changing accessories, or storing power tools.** Such preventive safety measures reduce the risk of starting the power tool accidentally.
- d) **Store idle power tools out of the reach of children and do not allow persons unfamiliar with the power tool or these instructions to operate the power tool.** Power tools are dangerous in the hands of untrained users.
- e) **Maintain power tools. Check for misalignment or binding of moving parts, breakage of parts and any other condition that may affect the power tools operation. If damaged, have the power tool repaired before use.** Many accidents are caused by poorly maintained power tools.
- f) **Keep cutting tools sharp and clean.** Properly maintained cutting tools with sharp cutting edges are less likely to bind and are easier to control.
- g) **Use the power tool, accessories and tool bits etc., in accordance with these instructions and in the manner intended for the particular type of power tool, taking into account the working conditions and the work to be performed.** Use of the power tool for operations different from those intended could result in a hazardous situation.
- 5) Service**
- a) **Have your power tool serviced by a qualified repair person using only identical replacement parts.** This will ensure that the safety of the power tool is maintained.



MULTIMASTER FMM 250 / MULTIMASTER FMM 250 Q

EN

## Special safety instructions.

**This double-insulated power tool is equipped with a polarized plug (one contact is wider than the other). The plug will only fit into the polarized socket outlet in one position. Turn the plug if it does not fit completely into the socket outlet. If the plug still does not fit, have a qualified electrician install a polarized socket outlet. Do not modify or alter the plug under any circumstances.** Double-insulated power tools neither require a three-core power cable nor a power connection with ground contact.

**Operate the power tool only off of power supplies whose voltage and frequency values correspond with the values on the type plate of the power tool.**

**When operating the power tool in a damp environment, it must be connected via a ground-fault circuit interrupter (g.f.c.i.).**

Using special rubber protective gloves and footwear increase your own safety.

**Use clamping devices or other suitable means to secure the workpiece to a firm surface.** Holding the workpiece by hand or pressing it against your body is not sufficient and can lead to loss of control.

**Before mounting or replacing application tools or accessories, pull the power plug.**

This preventive safety measure rules out the danger of injuries through accidental starting of the power tool.

**Hold the power tool by the insulated gripping surfaces when performing operations where the application tool could contact hidden wiring or its own power cord.** Contact with a "live" wire will also make exposed metal parts of the power tool "live" and shock the operator.

**Use appropriate detectors to determine if utility lines are hidden in the work area or call the local utility company for assistance.**

Contact with electric lines can lead to fire and electric shock. Damaging a gas line can lead to explosion. Penetrating a water line causes property damage or may cause an electric shock.

**Do not direct the power tool against yourself, other persons or animals.** Danger of injury from sharp or hot application tools.

**For all work or when changing application tools, always wear protective gloves.** Danger of injury from the sharp edges of the application tools. Application tools can become very hot while working. Danger of burns!

**Grasp the power tool in such a safe manner that your body never comes into contact with the application tool, especially while working with application tools such as saw blades or other blades pointed toward the grasping range.** Touching sharp tips or cutting edges can lead to injuries.

**The power tool is not permitted for operations or working with water supply.** Water penetrating the motor casing can lead to electric shock.

**Do not rivet or screw any name-plates or signs onto the power tool.** If the insulation is damaged, protection against an electric shock will be ineffective. Adhesive labels are recommended.

**Do not use accessories which are not specifically designed and recommended by the power tool manufacturer.** Safe operation is not ensured merely because an accessory fits your power tool.

**Clean the ventilation openings on the power tool at regular intervals. The motor blower draws dust into the housing.** An excessive accumulation of metallic dust can cause an electrical hazard.



## Handling Dusts Detrimental to Health

**⚠ WARNING** Some dusts created by sanding, sawing and other operations contain chemicals known to the State of California to cause cancer, birth defects and other reproductive harm.

Some examples of these chemicals are:

- Lead from lead-based paints.
- Crystalline silica from bricks and cement and other masonry products.
- Arsenic and chromium from chemically-treated lumber.

## Hand/arm vibrations

**⚠ WARNING** While working with this power tool, hand/arm vibrations occur. These can lead to health impairments.

**⚠ WARNING** The vibration emission value during actual use of the power tool can differ from the declared value depending on the ways in which the tool is used.

**⚠ WARNING** It is necessary to identify safety measures to protect the operator that are based on an estimation of exposure in the actual conditions of use (taking into account of all parts of the operating cycle such as the times when the tool is switched off and when it is running idle in addition to the trigger time).

Adopt the correct working practices in order to reduce the exposure to vibration:

- in the case of strong vibration, take the recommended work breaks or change your task more frequently,
- keep your hands warm,
- while working, only grip the power tool as firmly as necessary,
- work only with technically sound machines and application tools,

- Asbestos and materials containing asbestos.
- Wood dust from beech and oak wood. Your risk from these exposures varies, depending on how often you do this type of work. To reduce your exposure to these chemicals: work in a well ventilated area, and work with approved safety equipment, such as those dust masks that are specially designed to filter out microscopic particles.

- select the oscillating frequency according to the FEIN operating data; avoid resonance,
- use the FEIN vibration-absorbing, gel working gloves.

If these recommendations are not observed, the exposure to strong vibration during daily work over a longer period of time can be detrimental to health.

To prognosticate the vibration exposition, you can use the weighted acceleration value determined in the laboratory (see the Vibrations table). During work, weighted accelerations will be dependent on the particular application, and deviation from this laboratory value can occur.

## MULTIMASTER FMM 250 / MULTIMASTER FMM 250 Q

EN

**Emission values for sound and vibration** (Two-figure – specifications as per ISO 4871)**Sound emission**

Measured A-weighted sound power level

$L_{WA}$  (re 1 pW), in decibels: 85

Measuring uncertainty  $K_{WA}$ , in decibels: 3

A-weighted emission pressure power level measured at the workplace  $L_{pA}$  (re 20  $\mu$ Pa), in decibels: 74

Measuring uncertainty  $K_{pA}$ , in decibels: 3

REMARK: The sum of the measured emission value and respective measuring inaccuracy represents the upper limit of the values that can occur during measuring.



Wear ear protection!

Measured values determined in accordance with the corresponding product standard.

<b>Vibrations</b>	
Classification of FEIN application tools according to vibration class	Weighted acceleration*
VC0	< 2.5 m/s <sup>2</sup>
VC1	< 5 m/s <sup>2</sup>
VC2	< 7 m/s <sup>2</sup>
VC3	< 10 m/s <sup>2</sup>
VC4	< 15 m/s <sup>2</sup>
VC5	> 15 m/s <sup>2</sup>

\*These values are based on a work cycle consisting of no-load and full-load operation of the same duration.

**Extension cord**

**WARNING** If the use of an extension cable is required, its length and conductor cross-section must be adequate for the applicational case, in order to prevent a voltage drop in the extension cable, power loss and overheating of the power tool. Otherwise, the extension cable and power tool are liable to electrical danger, and the working efficiency is impaired.

**Recommended dimensions of extension cords at an operating voltage of 120 V – single-phase a. c., with only one power tool FMM 250/FMM 250 Q connected:**

Cord Size in A.W.G.			Wire Sizes in mm <sup>2</sup>		
18	16	14	0.75	1.5	2.5
Cord Length in Feet			Cord Length in Meters		
25	100	150	30	60	120

**EN**

MULTIMASTER FMM 250 / MULTIMASTER FMM 250 Q

## Intended use of the power tool.

This power tool is intended for commercial or private use for dry sanding of small surfaces, corners and edges, for scraping, for sawing thin steel sheet, wood and plastic components using the application tools and accessories recommended by FEIN.

With the respective accessories, the power tool can also be used for polishing, cutting, separating and as a rasp.

## Operation of the power tool off power generators.

**!** Operate the power tool only off a.c. generators with sufficient power output that do not have any distortion of the voltage curve.





**⚠ WARNING** Operating the power tool off power generators whose no-load speed exceeds the voltage value on the type plate of the power tool is prohibited.

## Symbols.

Symbol	Term, meaning	Explanation
	Action	Action to be taken by the user
	Do not touch the saw blade.	Danger of sharp application tools moving back and forth.
	General mandatory sign	Follow the instructions in the adjacent text!
	Read documentation	Be absolutely sure to read the enclosed documentation such as the Instruction Manual and the General Safety Instructions.
	Use eye-protection	Use eye-protection during operation.
	Wear ear protection	Use ear protection during operation.
	Use dust mask	Use a dust mask during operation.
	Use protective gloves	Use protective gloves during operation.
	It is forbidden to dispose of the product in the unsorted household waste.	Worn out power tools and other electro-technical and electrical products should be sorted separately for environment-friendly recycling.
	This symbol confirms the certification of this product for the USA and Canada.	

## MULTIMASTER FMM 250 / MULTIMASTER FMM 250 Q

EN

Symbol	Term, meaning	Explanation
 DANGER	DANGER	This sign warns of a directly imminent, dangerous situation. A false reaction can cause a severe or fatal injury.
 WARNING	WARNING	This sign indicates a possible dangerous situation that could cause severe or fatal injury.
 CAUTION	CAUTION	This sign warns of a possible dangerous situation that could cause injury.
	Protective class II	Product with double or reinforced insulation
mm	Millimeter	Unit of measure for length, width, height or depth
kg	Kilogram	Unit of measure for the mass
V	Volt	Unit of measure for the electric voltage
A	Ampere	Unit of measure for the electric current intensity
W	Watt	Unit of measure for the output
min	per minute	Unit of measure for number of revolutions, strokes, impacts or oscillations per minute
°	Degree	Unit of measure for the angle width
~ or a. c.	Current type	Alternating current
1 ~	Power supply type	Alternating current single-phase
$n_o$	No-load speed	Revolution speed at no-load
1/min	per minute	Unit of measure for number of revolutions, strokes, impacts or oscillations per minute
∅	Diameter	Diameter of a round part

## Technical description and specifications.

 **WARNING** Before mounting or replacing application tools or accessories, pull the power plug. This preventive safety measure rules out the danger of injuries through accidental starting of the power tool.

**EN**

MULTIMASTER FMM 250 / MULTIMASTER FMM 250 Q

Only part of the accessories described or shown in this instruction manual will be included with your power tool.

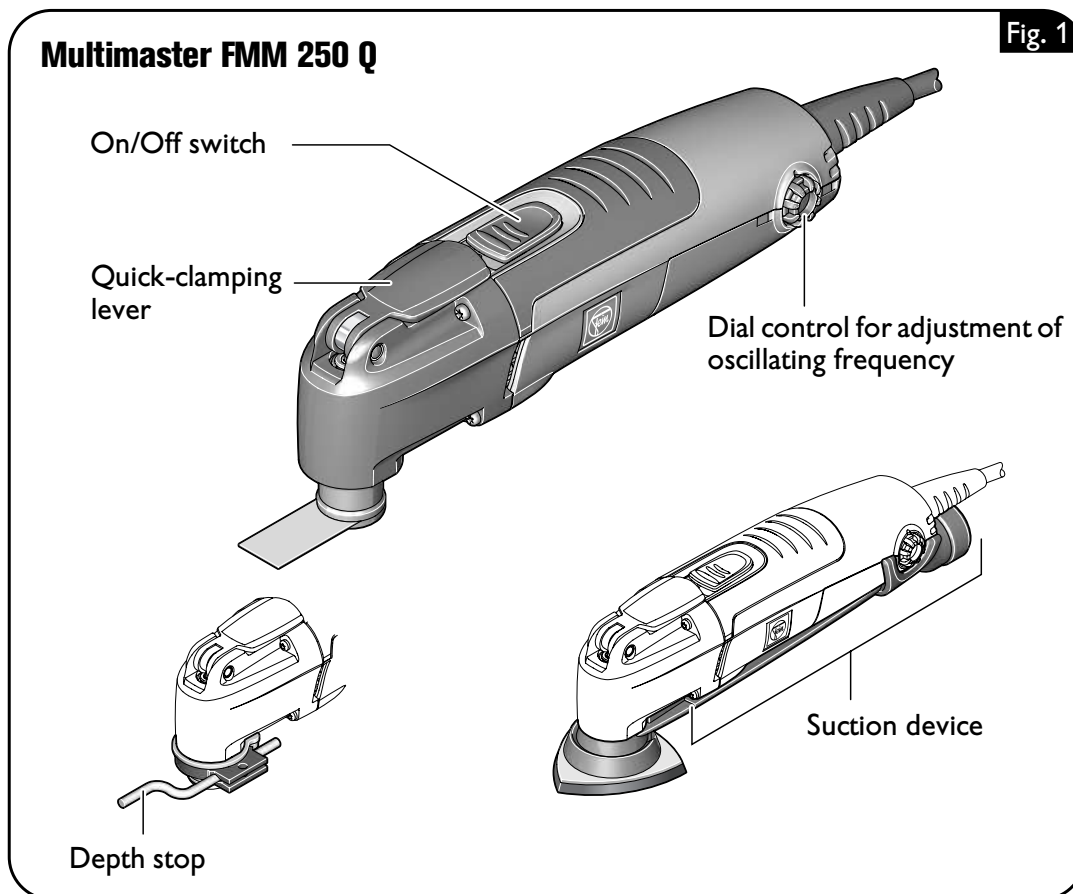

Type	MULTIMASTER FMM 250	MULTIMASTER FMM 250 Q
Reference number	7 229 36	7 229 37
Rated voltage	120 V/60 Hz	120 V/60 Hz
Power Input	250 W	250 W
Output	140 W	140 W
Current	2.3 A	2.3 A
Power supply type	1 ~	1 ~
Oscillating frequency	11 000–20 000/min	11 000–20 000/min
Weight according to EPTA-Procedure 01/2003	1.2 kg	1.4 kg
Class of protection	II □	II □
Oscillating angle	1.6 °	1.6 °

## Assembly instructions.

### Mounting the suction device (Figure 2).

**⚠ WARNING** Before mounting or replacing application tools or accessories, pull the power plug. This preventive safety measure rules out the danger of injuries through accidental starting of the power tool.

- Mount the suction device step by step as shown in the figures.
- For connection with a FEIN Dustex or a vacuum cleaner, various hose adapters are available as an accessory.
- To remove the suction device again, push the clamp at the rear (8).

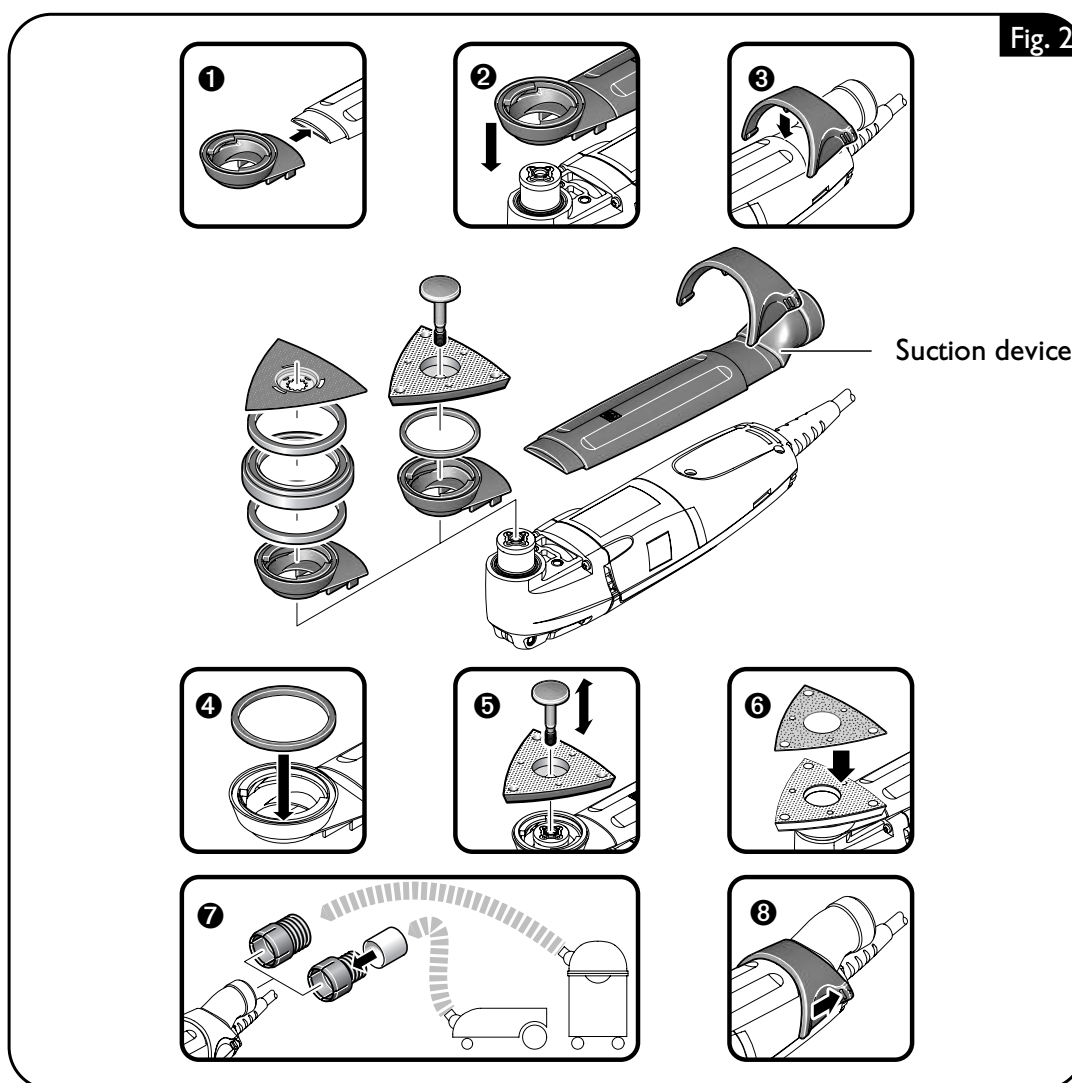

## Changing the tool.

-  The application tool can be fastened offset at convenient working positions at 45° steps (or at 30° steps for the triangle-shaped sanding pad).

### MULTIMASTER FMM 250 Q (Figure 3).

**⚠ WARNING** Before mounting or replacing application tools or accessories, pull the power plug. This preventive safety measure rules out the danger of injuries through accidental starting of the power tool.

**⚠ CAUTION** For all work or when changing application tools, always wear protective gloves. Danger of injury from the sharp edges of the application tools. Application tools can become very hot while working. Danger of burns!

- Loosen the quick-clamping lever and swivel it to the stop.
- Pull out the fastening element.
- Clean the tool holder, the application tool and the fastening element.
- Place the application tool exactly onto the star-shaped tool holder. Pay attention that the application tool has a flush fit.
- Insert the fastening element to the stop into the tool holder.
- Swivel the quick-clamping lever back until it engages.

**⚠ CAUTION** Protect your hand and fingers from being bruised/crushed from the snapping back quick-clamping lever. The quick-clamping lever pivots back powerfully due to the spring force.

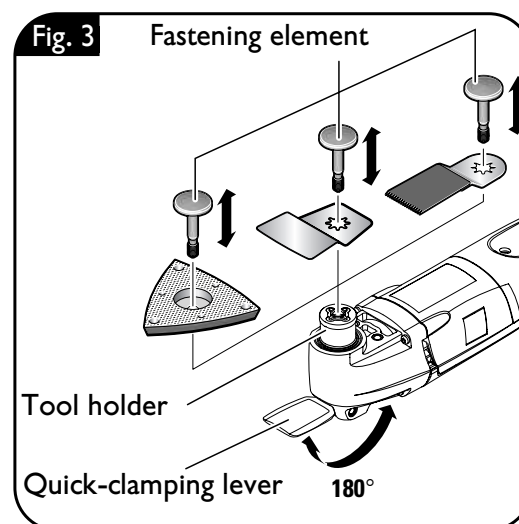

**MULTIMASTER FMM 250 (Figure 4).**

**⚠ WARNING** Before mounting or replacing application tools or accessories, pull the power plug. This preventive safety measure rules out the danger of injuries through accidental starting of the power tool.

**⚠ CAUTION** For all work or when changing application tools, always wear protective gloves. Danger of injury from the sharp edges of the application tools. Application tools can become very hot while working. Danger of burns!

- Unscrew the clamping screw.
- Clean the tool holder, the application tool and the clamping screw.
- Place the application tool exactly onto the star-shaped tool holder. Pay attention that the application tool has a flush fit.
- Tighten the clamping screw using the supplied Allen key.

**Attaching/replacing the sanding sheet (Figure 5).**

- Align the sanding sheet and press it onto the sanding plate by hand.
- Firmly press the power tool with the sanding sheet against a flat surface and briefly switch the power tool on. This provides for good adhesion and prevents premature wear.

The sanding sheet can be pulled off again and then remounted offset by 120° when only one tip of the sanding sheet is worn.

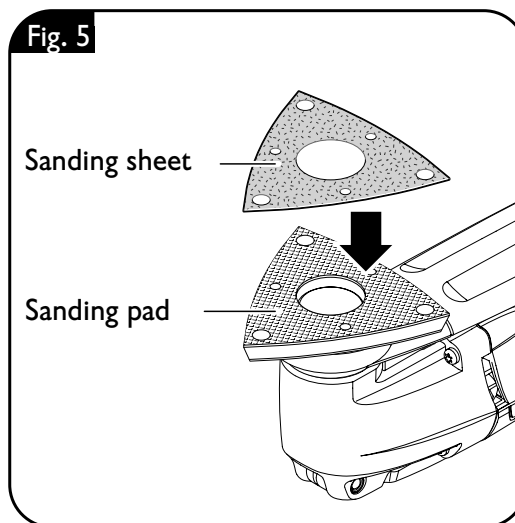
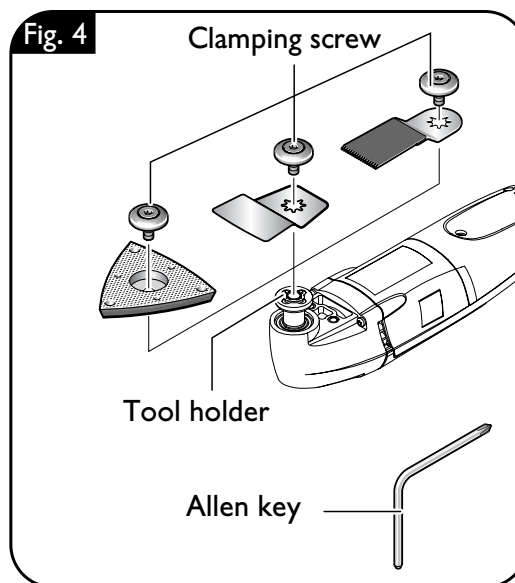

**EN**

MULTIMASTER FMM 250 / MULTIMASTER FMM 250 Q

## Working instructions.

**⚠ WARNING** Before mounting or replacing application tools or accessories, pull the power plug. This preventive safety measure rules out the danger of injuries through accidental starting of the power tool.

**!** For each job, use only the FEIN application tool released and intended for the respective application.

### Connecting the dust extraction (Figure 2, ⑦).

**⚠ CAUTION** When working materials that produce dust, the power tool is to be connected to an external dust extraction via the extraction adapter.

The vacuum cleaner must be suitable for the material being worked.

When vacuuming dry dusts that are particularly hazardous to one's health or carcinogenic, a specialty vacuum cleaner is to be used.

### Switching ON and OFF (Figure 1).

**⚠ WARNING** First check that the power cable and power plug are not damaged.

**⚠ CAUTION** Always hold the power tool firmly. Otherwise, you could lose control over the power tool.

#### Switching ON:

➤ Push the switch towards the front (I).

#### Switching OFF:

➤ Push the switch towards the back (0).

### Setting the oscillating frequency (Figure 1).

The oscillating frequency can be set infinitely variable with the dial control.

Increasing the oscillating frequency:

➤ Turn dial control in counterclockwise direction.

Decreasing the oscillating frequency:

➤ Turn dial control in clockwise direction.

The oscillating frequency depends on the application and the application tool. Example:

- High oscillating frequency:  
Sanding, sawing, using as a rasp, polishing stone and metal.
- Low oscillating frequency:  
Polishing of varnish and veneers, removal of grout, teak decks from boats.

### Securing the work piece.

**⚠ CAUTION** Secure the workpiece firmly. A work piece that is gripped tightly in a clamping device or vice, is more secure than if held by hand.

### Sanding

Typical application: Dry sanding of wood and metal, especially of smaller surfaces, corners and edges, as well as hard to reach locations.

Work with the complete surface of the sanding plate, not only with the tip. Select a high oscillating frequency. Sand with continuous motion and light pressure. **Applying excessive pressure does not increase material removal; only the sanding sheet wears more quickly.**

### Sawing

Typical application: Sawing of thin steel sheet, wood and plastic components.

Select a high oscillating frequency.

## MULTIMASTER FMM 250 / MULTIMASTER FMM 250 Q

EN

Round saw blades can be clamped offset again to provide uniform wear.

### Scraping

Typical application: Scraping off old coats of varnish or adhesives, removing bonded carpeting, e. g., on stairs/steps or other small/medium-sized surfaces.

Select a medium to high oscillating frequency.

For further information as well as tips on polishing, cutting, separating and using as a rasp, see the booklet "Ideas for Usage".

### Maintenance.

**WARNING** Before mounting or replacing application tools or accessories, pull the power plug. This preventive safety measure rules out the danger of injuries through accidental starting of the power tool.

### Service

**WARNING** Have maintenance carried out only through qualified personnel. Incorrectly mounted leads and components can cause serious injuries. Have the required service carried out only through a FEIN customer service agent.

### Cleaning

**WARNING** Prior to any cleaning or maintenance, disconnect the power tool from the power supply in order to avoid accidents. It is best to clean the power tool with dry compressed air. When cleaning power tools with compressed air, always wear safety goggles.

**WARNING** When working metal under extreme operating conditions, it is possible for conductive dust to settle in the interior of the power tool. The total insulation of the power tool can be impaired. For such cases, frequent blowing out the ventilation slots and connecting a ground-fault circuit interrupter (g.f.c.i.) in series is recommended.

### Storage

(MULTIMASTER FMM 250 Q - Figure 3).

**WARNING** Before carrying out adjustments on the power tool, replacing accessories or placing down the power tool, pull the plug from the socket outlet. This safety measure prevents accidental starting of the power tool.

- ▶ Engage the quick-clamping lever.
- ▶ Fully insert the fastening element into the tool holder in order to protect it against damage and contamination.

Cooling-air openings and operating elements must be clean and may not be obstructed through other objects. Do not attempt to clean the openings with pointed objects.

- ! Use non-metallic tools to clean the air vents.
- ! Cleaning agents and solvents can cause damage to plastic parts. These include: Gasoline, carbon-tetrachloride, chloric solvents, ammonia and domestic cleaning agents that contain ammonia.
- ! When the power tool's power cable is damaged, it must be replaced by a qualified person using a specially prepared power cable, available from your FEIN customer service agent.

### Accessories.

Only use accessories recommended by FEIN.

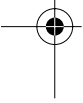
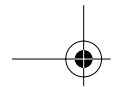

**EN**

MULTIMASTER FMM 250 / MULTIMASTER FMM 250 Q

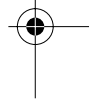

## **Warranty and liability.**

The warranty for the product is valid in accordance with the legal regulations in the country where it is marketed.

In addition, FEIN also provides a guarantee in accordance with the FEIN manufacturer's guarantee. For further details on this, please contact your specialist dealer, your national FEIN representative, or the FEIN customer service centre.

## **Environmental protection, disposal.**

Packaging, worn out power tools and accessories should be sorted for environment-friendly recycling. Further information can be obtained from your specialist dealer.

