

INSTRUCTION MANUAL  
MANUEL D'INSTRUCTION  
MANUAL DE INSTRUCCIONES

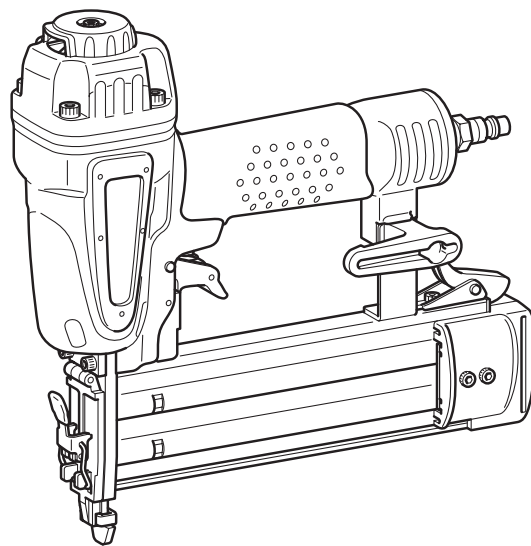

# Pneumatic Brad Nailer Cloueur Pneumatique Polyvalent Clavadora Neumática para Clavos de Cabeza Redonda

**AF505N**



**IMPORTANT:** Read Before Using.  
**IMPORTANT :** Lire avant usage.  
**IMPORTANTE:** Lea antes de usar.

# SPECIFICATIONS

Model	AF505N
Air pressure	0.39 - 0.78 MPa (60 - 115 PSIG)
Nail length	15 mm (5/8") - 50 mm (2")
Nail capacity	100 pcs.
Min. hose diameter	6.5 mm (1/4")
Dimensions (L X H X W)	260 mm X 237 mm X 64 mm (10-1/4" X 9-5/8" X 2-1/2")
Net weight	1.4 kg (3.01 lbs)

- Due to our continuing program of research and development, the specifications herein are subject to change without notice.
- Note: Specifications may differ from country to country.

## Important safety instructions

For personal safety and proper operation and maintenance of the tool, read this instruction manual carefully before using the tool.

**WARNING: WHEN USING THIS TOOL, BASIC SAFETY PRECAUTIONS SHOULD ALWAYS BE FOLLOWED TO REDUCE THE RISK OF PERSONAL INJURY, INCLUDING THE FOLLOWING:**

## READ ALL INSTRUCTIONS.

### Personal Protective Equipment

1. Always wear safety glasses to avoid eye injury from dust or fasteners. The safety glasses should conform with the requirements of ANSI Z87.1. **WARNING:** It is an employer's responsibility to enforce the use of safety eye protection equipment by the tool operators and by other persons in the immediate working area.
2. Wear hearing protection to protect your ears against exhaust noise and head protection. Also wear light but not loose clothing. Sleeves should be buttoned or rolled up. No necktie should be worn.

### Flammable Atmospheres

1. Do not operate tool in explosive atmospheres, such as in the presence of flammable liquids, gases or combustible dust.

### Tool modification

1. The tool should not be modified unless authorized in the tool manual or approved in writing by the tool manufacturer.

### Tool maintenance

1. Refer to the tool maintenance instructions for detailed information on the proper maintenance of a tool.

### Recommended fasteners and accessories

1. Use only fasteners made or recommended by the tool manufacturer, or fasteners that perform equivalently to those recommended by the manufacturer.
2. Use only accessories made or recommended by the tool manufacturer, or accessories that perform equivalently to those recommended by the manufacturer.

### Inspect tool before operating to:

1. Use only power source specified in the instruction manual.  
Operate the tool within the specified air pressure on the tool label for safety and longer tool life. Do not exceed the recommended max. operating pressure. The tool should not be connected to a source whose pressure potentially exceeds 1.37 MPa (200 PSIG).
2. Never use the tool with other than compressed air. If bottled gas (carbon dioxide, oxygen, nitrogen, hydrogen, air, etc.) or combustible gas (hydrogen, propane, acetylene, etc.) is used as a power source for this tool, the tool will explode and cause serious injury.
3. Always check the tool for its overall condition and loose screws before operation. Tighten as required.
4. Make sure all safety systems are in working order before operation. The tool must not operate if only the trigger is pulled or if only the contact element is pressed against the wood. It must work only when both actions are performed. Test for possible faulty operation with fasteners unloaded and the contact element in fully pulled position.
5. Always check contact element as instructed in this manual. Fasteners may be driven accidentally if the safety mechanism is not working correctly.

### Operating controls

1. Do not use a tool with missing or damaged safety warning label(s.)
2. A tool that is not in proper working order must not be used. Tags and physical segregation shall be used for control.
3. Do not remove, tamper with, or otherwise cause tool operating controls to become inoperable.
4. Do not operate tool if any portion of the tool operating controls is inoperable, disconnected, altered, or not working properly.

### Tool handling

1. Only persons who have read and understand the tool operating/safety instructions should operate the tool.
2. Always assume that tool contains fasteners.

3. Do not point tool toward yourself or anyone whether it contains fasteners or not.
4. Keep bystanders and children away while operating tool.
5. Do not actuate tool unless tool is placed firmly against the workpiece.
6. Respect tool as a working implement.
7. Do not engage in horseplay.
8. Stay alert, focus on your work and use common sense when working with tools.
9. Do not use tool while tired, after having consumed drugs or alcohol, or while under the influence of medication.
10. Do not overreach. Keep proper footing and balance at all times.
11. Do not hold or carry tool with a finger on the trigger.
12. Drive fasteners into proper work surface only.
13. Do not drive fasteners into other fasteners.
14. After driving a fastener, tool may spring back (“recoil”) causing it to move away from the work surface. To reduce risk of injury always manage recoil by:
  - a) always maintaining control of tool.
  - b) allowing recoil to move tool away from work surface.
  - c) not resisting recoil such that tool will be forced back into the work surface. In “Contact Actuation Mode,” if workpiece contact is allowed to re-contact work surface before the trigger is released, an unintended discharge of a fastener will occur.
  - d) keeping face and body parts away from tool.
15. When working close to an edge of a workpiece or at steep angles use care to minimize chipping, splitting or splintering, or free flight or ricochet of fasteners, which may cause injury.
16. Keep hands and body away from fastener discharge area of tool.
17. Do not load tool with fasteners when any one of the operating controls is activated.
18. Do not operate tool with any power source other than that specified in tool operating/ safety instructions.
19. Do not operate tool with any operating pressure other than that specified in tool operating/ safety instructions.
20. Always select an actuation system that is appropriate to the fastener application and the training of the operator.
21. Use extra caution when driving fasteners into existing walls or other blind areas to prevent contact with hidden objects or persons on other side (e.g., wires, pipes.)
22. Do not lift, pull or lower tool by the hose.

#### Disconnecting tool

Disconnect tool from the power source when:

1. Not in use;
2. Performing any maintenance or repairs;
3. Clearing a jam;
4. Elevating, lowering or otherwise moving the tool to a new location;

5. Tool is outside of the operator’s supervision or control; or

6. Removing fasteners from the magazine.

#### Additional safety instructions

1. The area should be sufficiently illuminated to assure safe operations. The area should be clear and litter-free.
2. There may be local regulations concerning noise which must be complied with by keeping noise levels within prescribed limits. In certain cases, shutters should be used to contain noise.
3. Check walls, ceilings, floors, roofing and the like carefully to avoid possible electrical shock, gas leakage, explosions, etc. caused by striking live wires, conduits or gas pipes.
4. On rooftops and other high locations, drive fasteners as you move forward. It is easy to lose your footing if you drive fasteners while inching backward. When driving against perpendicular surface, drive fasteners from the top to the bottom. You can perform the operations with less fatigue by doing so.
5. Do not leave the loaded tool or the air compressor under pressure for a long time out in the sun. Be sure that dust, sand, chips and foreign matter will not enter the tool in the place where you leave it setting.
6. Perform cleaning and maintenance right after finishing the job. Keep the tool in tip-top condition. Lubricate moving parts to prevent rusting and minimize friction-related wear. Wipe off all dust from the parts.
7. Do not disconnect the air hose with a finger on the trigger. An unexpected driving will cause serious injury when the air hose is connected.
8. When you drop or strike the tool, check the tool damage or crack and make sure that safety systems are in working order before operation. As there is high pressure inside the tool, failure to do so will cause serious injury.
9. Ask Makita’s Authorized service centers for periodical inspection of the tool.
10. To maintain product SAFETY and RELIABILITY, maintenance and repairs should be performed by Makita Authorized or Factory Service Centers, always using Makita replacement parts.

## SAVE THESE INSTRUCTIONS.

**⚠ WARNING:** MISUSE or failure to follow the safety rules stated in this instruction manual may cause serious personal injury.

## Symbols

The followings show the symbols used for tool.



Read and understand tool labels and manual. Failure to follow warnings could result in death or serious injury.



Operators and others in work area must wear safety glasses with side shields.



Keep fingers away from trigger when not driving fasteners to avoid accidental discharge.

# INSTALLATION

## Selecting compressor

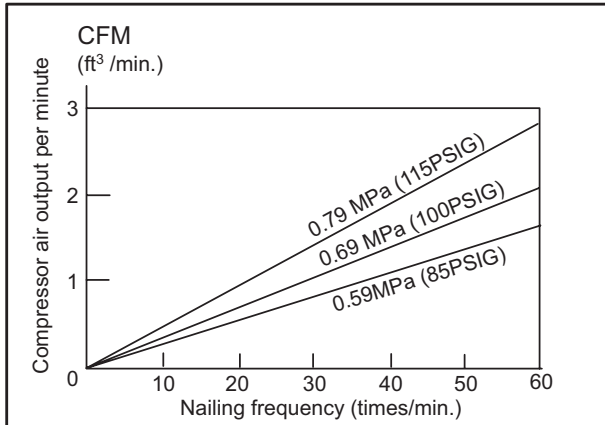

The air compressor must comply with the requirements of ANSI B19.3.

Select a compressor that has ample pressure and air output to assure cost-efficient operation. The graph shows the relation between nailing frequency, applicable pressure and compressor air output.

Thus, for example, if nailing takes place at a rate of approximately 60 times per minute at a compression of 0.69 MPa (100 PSIG), a compressor with an air output over 2 CFM (ft<sup>3</sup>/minute) is required.

Pressure regulators must be used to limit air pressure to the rated pressure of the tool where air supply pressure exceeds the tool's rated pressure. Failure to do so may result in serious injury to tool operator or persons in the vicinity.

## Selecting air hose

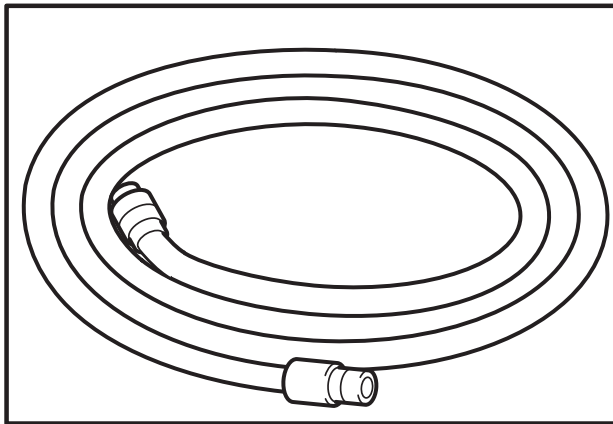

Use an air hose as large and as short as possible to assure continuous, efficient nailing operation. With an air pressure of 0.49 MPa (70 PSIG), an air hose with an internal diameter of over 6.5 mm (1/4") and a length of less than 20 m (6.6 ft.) is recommended when the interval between each nailing is 0.5 seconds. Air supply hoses shall have a minimum working pressure rating of 1.03 MPa (150 PSIG) or 150 percent of the maximum pressure produced in the system whichever is higher.

### ⚠ CAUTION:

- Low air output of the compressor, or a long or smaller diameter air hose in relation to the nailing frequency may cause a decrease in the driving capability of the tool.

## Lubrication

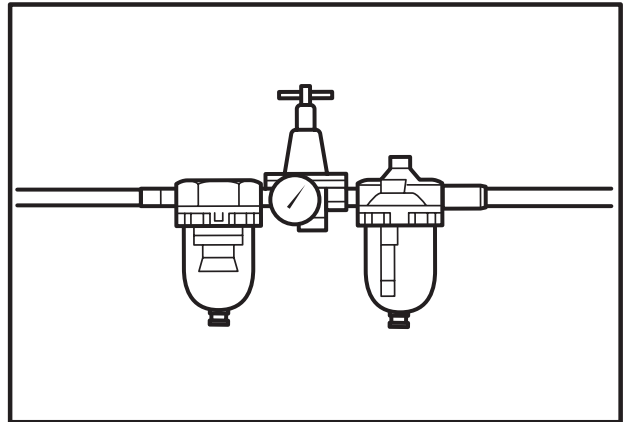

To insure maximum performance, install an air set (oiler, regulator, air filter) as close as possible to the tool.

Adjust the oiler so that one drop of oil will be provided for every 50 nails.

When an air set is not used, oil the tool with pneumatic tool oil by placing 2 (two) or 3 (three) drops into the air fitting. This should be done before and after use. For proper lubrication, the tool must be fired a couple of times after pneumatic tool oil is introduced.

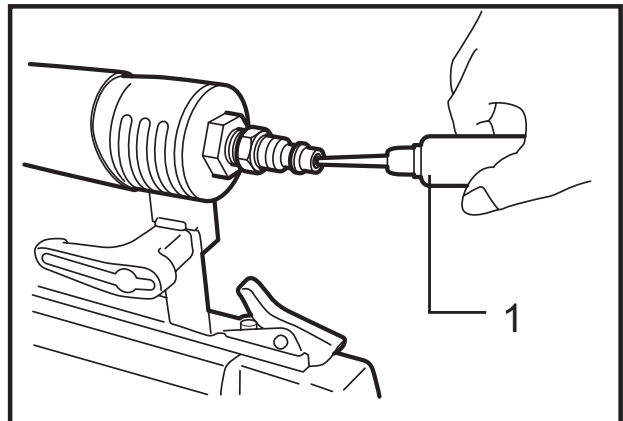

► 1. Pneumatic tool oil

# FUNCTIONAL DESCRIPTION

## ⚠ CAUTION:

- Always disconnect the hose before adjusting or checking function on the tool.

## Adjusting depth of nailing

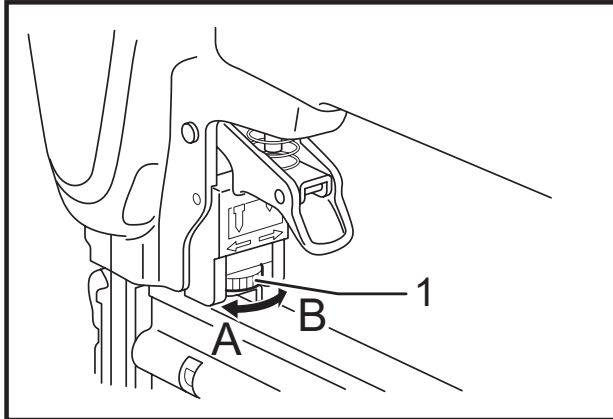

► 1. Adjuster

To adjust the depth of nailing, turn the adjuster. The depth of nailing is the deepest when the adjuster is turned fully in the A direction shown in the figure. It will become shallower as the adjuster is turned in the B direction. If nails cannot be driven deep enough even when the adjuster is turned fully in the A direction, increase the air pressure. If nails are driven too deep even when the adjuster is turned fully in the B direction, decrease the air pressure. Generally speaking, the tool service life will be longer when the tool is used with lower air pressure and the adjuster set to a lower depth of nail driving.

## ⚠ CAUTION:

- Always disconnect the hose before adjusting the depth of nailing.

## Hook

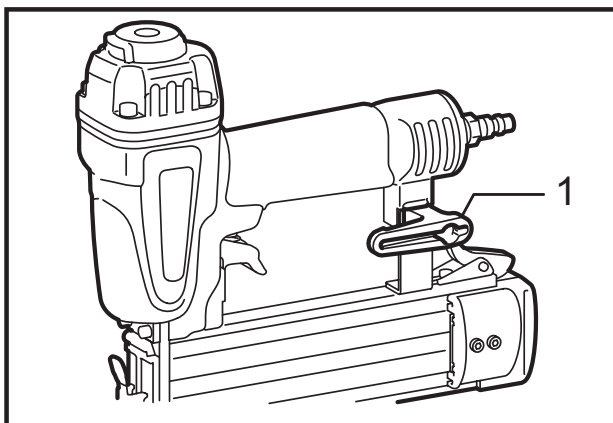

► 1. Hook

## ⚠ CAUTION:

- Always disconnect the hose from the tool.
- Never hook the tool at high location or on potentially unstable surface.

The hook is convenient for hanging the tool temporarily.

# ASSEMBLY

## ⚠ CAUTION:

- Always disconnect the hose before carrying out any work on the tool.
- Load the same kind, size and uniform length of nails when loading nails in the magazine.

## Loading nailer

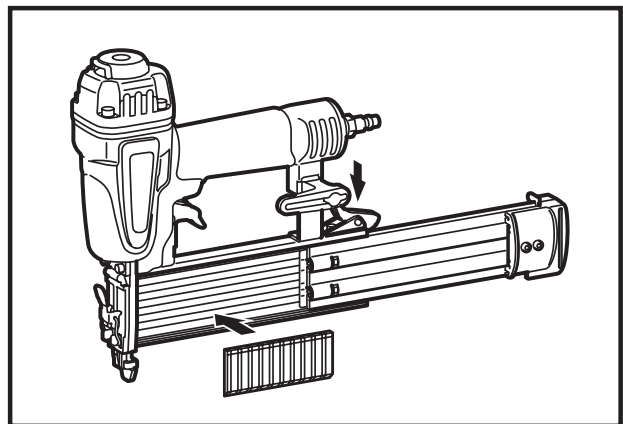

Press the lever and open the sliding door of the magazine by pulling it toward yourself with the lever pressed. Align the tip of nails with the grooves at the bottom of the magazine and push the whole part of nails toward the firing opening.

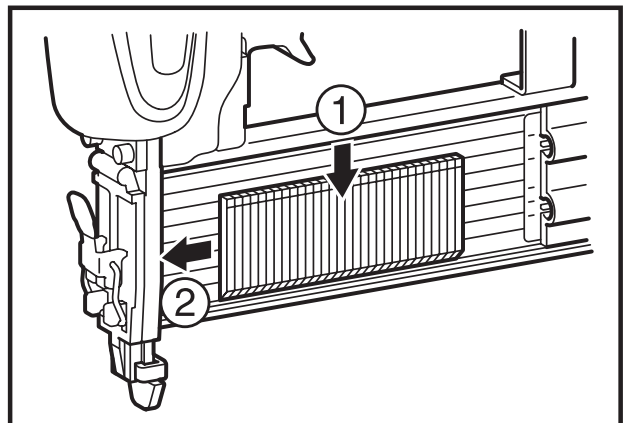

Close the sliding door.

## Nose adapter

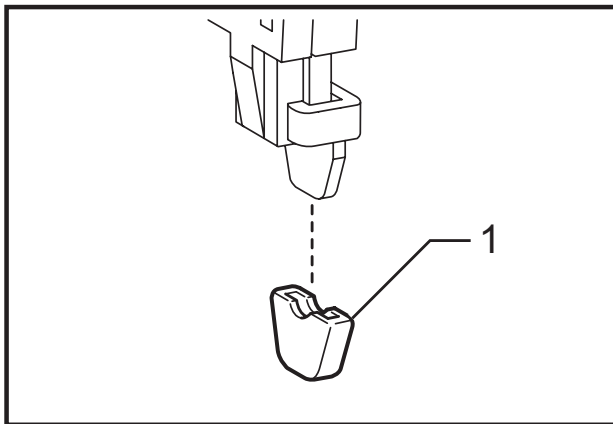

► 1. Nose adapter

### ⚠ CAUTION:

- Always disconnect the hose before installing the nose adapter.

To prevent the surface of workpiece from being scratched or damaged, use the nose adapter.

## Connecting air hose

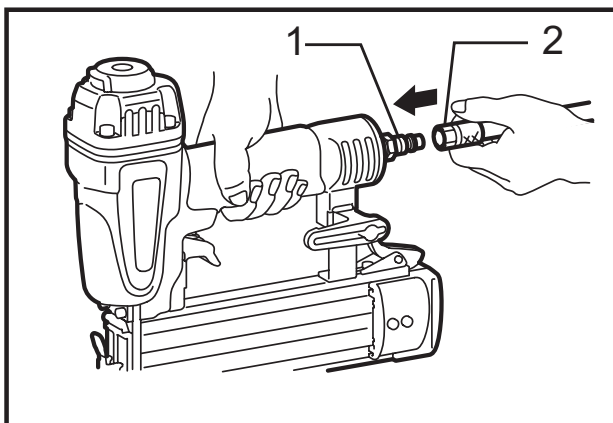

► 1. Air fitting 2. Air socket

Slip the air socket of the air hose onto the air fitting on the nailer. Be sure that the air socket locks firmly into position when installed onto the air fitting. A hose coupling must be installed on or near the tool in such a way that the pressure reservoir will discharge at the time the air supply coupling is disconnected.

## OPERATION

To drive a nail, you may place the contact element against the workpiece and pull the trigger.

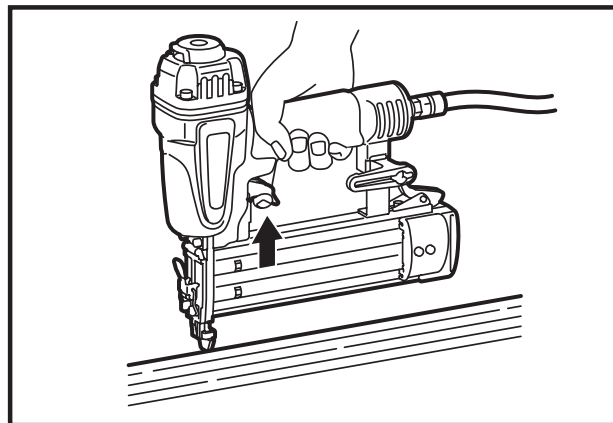

### ⚠ CAUTION:

- WITH THE TRIGGER HELD IN A HALF-PULLED POSITION, an unexpected nailing could occur, if contact element is allowed to re-contact against the workpiece or the other surface under the influence of recoil. In order to avoid this unexpected nailing, perform as follows;

- A. Do not place the contact element against the workpiece with excessive force.
- B. Pull the trigger fully and hold it on for 1-2 seconds after nailing.

## Direction of exhaust air

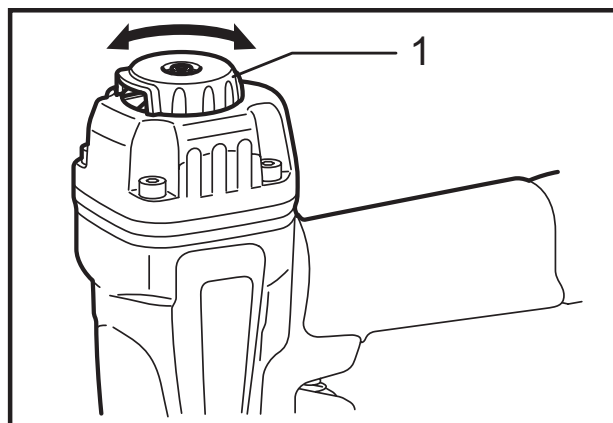

► 1. Exhaust cover

The direction of exhaust air can be changed 360 degrees of angle by turning the exhaust cover with a hand.

## Removing nails

### ⚠ CAUTION:

- Do not use deformed nails or nail strip. Failure to do so causes poor nail feeding.

**⚠ WARNING:**

- Always disconnect the hose before removing nails.

Open the slide door and remove nails from the magazine.

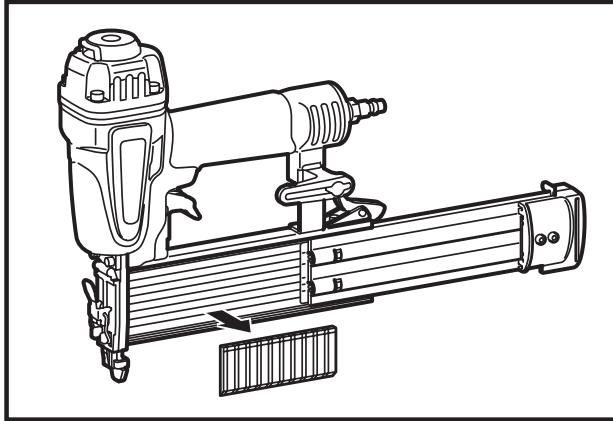

With the slide door kept open, open the door and take out nails.  
Removing the contact top allows nails to be easily taken out. When re-installing the contact top, insert the protrusion of the contact top into the notch in the contact arm.

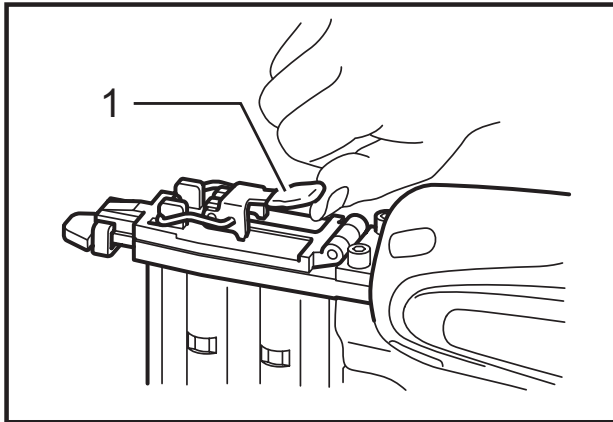

▶ 1. Latch

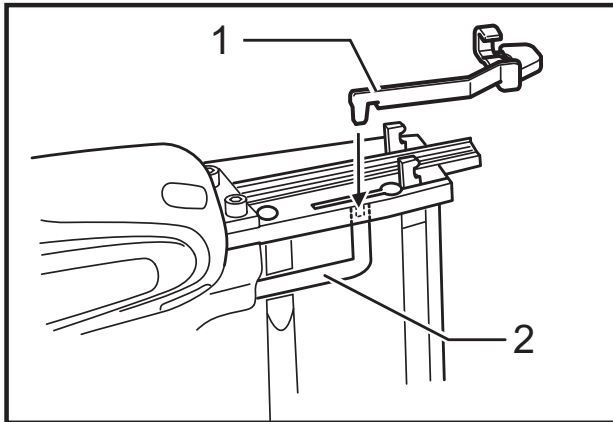

▶ 1. Contact top 2. Contact arm

## Nails

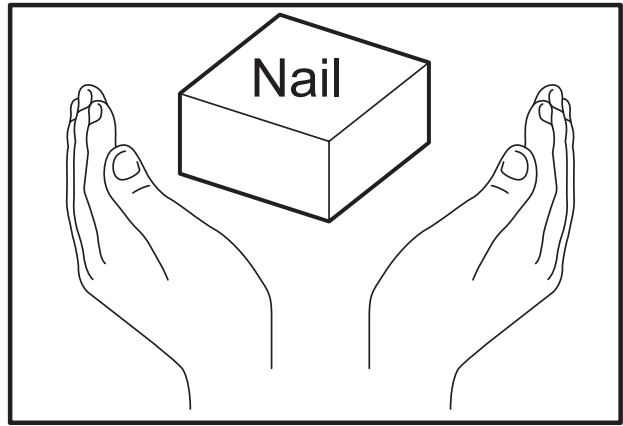

Handle nail coils and their box carefully. If the nail coils have been handled roughly, they may be out of shape or their connector breaks, causing poor nail feed. Avoid storing nails in a very humid or hot place or place exposed to direct sunlight.

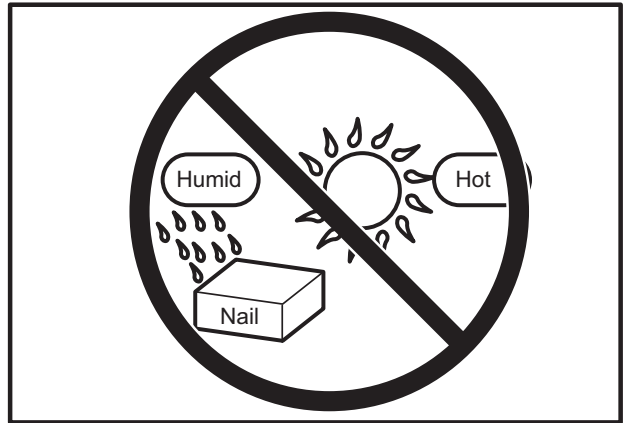

## MAINTENANCE

**⚠ CAUTION:**

- Always disconnect the air hose from the tool before attempting to perform inspection or maintenance.
- Never use gasoline, benzine, thinner, alcohol or the like. Discoloration, deformation or cracks may result.

## Maintenance of nailer

Always check the tool for its overall condition and loose screws before operation. Tighten as required.

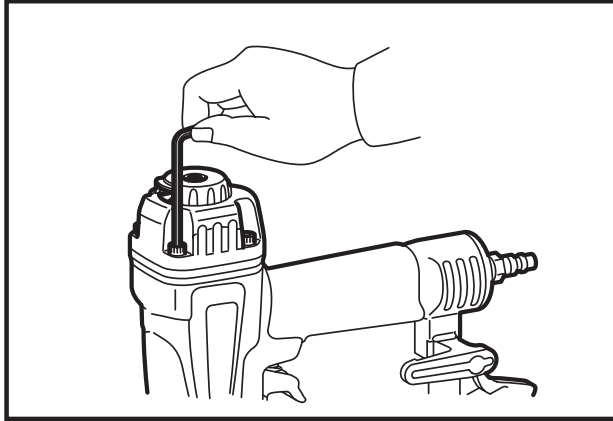

With tool disconnected, make daily inspection to assure free movement of the contact element and trigger. Do not use tool if the contact element or trigger sticks or binds.

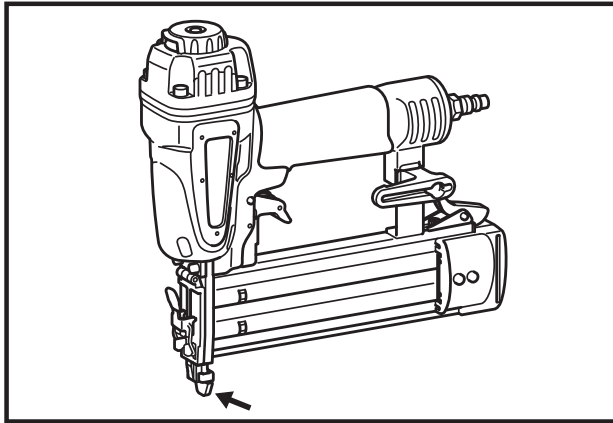

When the tool is not to be used for an extended period of time, lubricate the tool using pneumatic tool oil and store the tool in a safe place. Avoid exposure to direct sunlight and/or humid or hot environment.

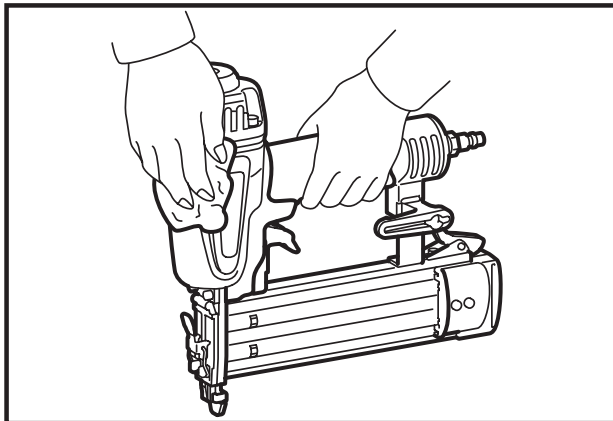

## Maintenance of compressor, air set and air hose

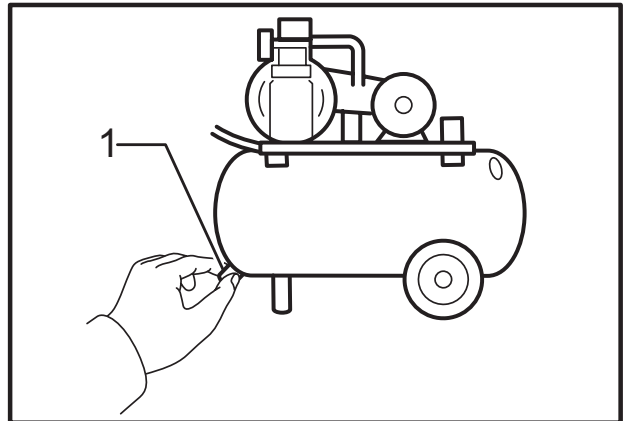

► 1. Drain cock

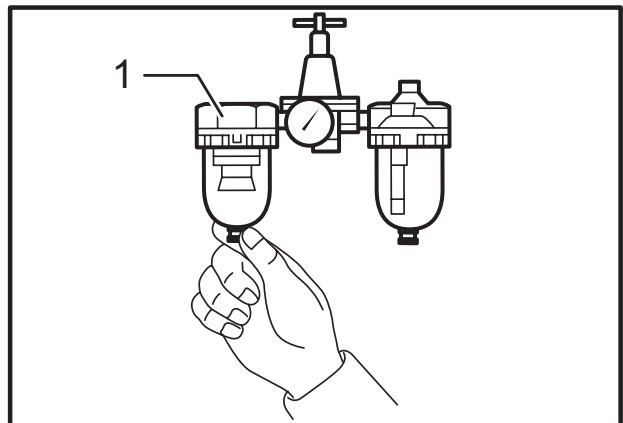

► 1. Air filter

After operation, always drain the compressor tank and the air filter. If moisture is allowed to enter the tool, it may result in poor performance and possible tool failure.

Check regularly to see if there is sufficient pneumatic oil in the oiler of the air set. Failure to maintain sufficient lubrication will cause O-rings to wear quickly.

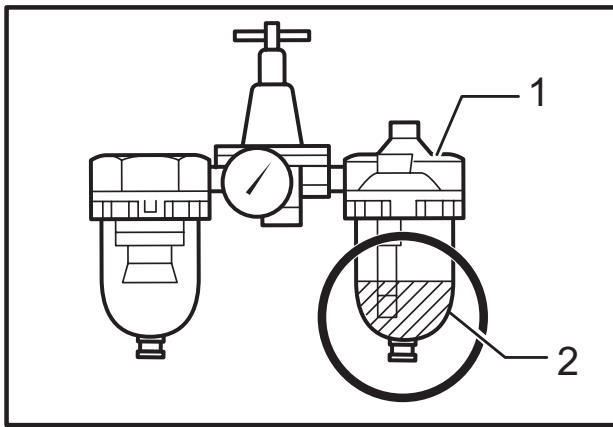

► 1. Oiler 2. Pneumatic oil

Keep the air hose away from heat (over 60°C, over 140°F), away from chemicals (thinner, strong acids or alkalis). Also, route the hose away from obstacles which it may become dangerously caught on during operation. Hoses must also be directed away from sharp edges and areas which may lead to damage or abrasion to the hose.



To maintain product SAFETY and RELIABILITY, repairs, any other maintenance or adjustment should be performed by Makita Authorized or Factory Service Centers, always using Makita replacement parts.

## OPTIONAL ACCESSORIES

### ⚠ CAUTION:

- These accessories or attachments are recommended for use with your Makita tool specified in this manual. The use of any other accessories or attachments might present a risk of injury to persons. Only use accessory or attachment for its stated purpose.

If you need any assistance for more details regarding these accessories, ask your local Makita Service Center.

- Nails
- Air hoses
- Safety goggles

### NOTE:

- Some items in the list may be included in the tool package as standard accessories. They may differ from country to country.

# WARNING

Some dust created by power sanding, sawing, grinding, drilling, and other construction activities contains chemicals known to the State of California to cause cancer, birth defects or other reproductive harm. Some examples of these chemicals are:

- lead from lead-based paints,
- crystalline silica from bricks and cement and other masonry products, and
- arsenic and chromium from chemically-treated lumber.

Your risk from these exposures varies, depending on how often you do this type of work. To reduce your exposure to these chemicals: work in a well ventilated area, and work with approved safety equipment, such as those dust masks that are specially designed to filter out microscopic particles.

< Sólo en los Estados Unidos >

# ADVERTENCIA

Algunos polvos creados por el lijado, aserrado, esmerilado, taladrado y otras actividades de la construcción contienen sustancias químicas reconocidas por el Estado de California como causantes de cáncer, defectos de nacimiento y otros peligros de reproducción. Algunos ejemplos de estos productos químicos son:

- plomo de pinturas a base de plomo,
- sílice cristalino de ladrillos y cemento y otros productos de albañilería, y
- arsénico y cromo de maderas tratadas químicamente.

El riesgo al que se expone varía, dependiendo de la frecuencia con la que realice este tipo de trabajo. Para reducir la exposición a estos productos químicos: trabaje en un área bien ventilada y póngase el equipo de seguridad indicado, tal como las máscaras contra polvo que están especialmente diseñadas para filtrar partículas microscópicas.

**Makita Corporation**

3-11-8, Sumiyoshi-cho,  
Anjo, Aichi 446-8502 Japan

[www.makita.com](http://www.makita.com)

AF505N-NA3-0316  
EN, FRCA, ESMX  
20160325